

## ROBUSTNESS OF THE SD WATERMARKING ALGORITHM IN IS MAPPING ON FILTERING AUDIO SIGNALS USING NOTCH FILTERING

Bojan Prlinčević<sup>1</sup>, Zoran Milivojević<sup>2</sup>, Milan Misić<sup>1</sup>

<sup>1</sup>Kosovo and Metohija Academy of Applied Studies, Leposavic, Serbia

<sup>2</sup>Academy of Applied Technical and Preschool Studies, Nis, Serbia

### Abstract

In this paper, robustness analysis of SD watermarking algorithm in IS mapping using Notch filter audio signal filtering has been performed. The first part of the paper describes SD algorithm for inserting and extracting a watermark into an image. After that, conversion of the image has been performed, with inserted watermark into audio signal and Notch filtering. The second part of the paper presents an experiment in which robustness of the Schur algorithm in relation to Notch filtering has been tested. The Notch filter has been realized with width- $r$  and center- $\theta$  of impermeable bandwidth. The obtained results were analyzed using objective (MSE and NC) and subjective (visual quality) quality measures.

**Keywords:** Schur decomposition; watermarking, Notch filter.

### INTRODUCTION

The rapid development of modern information and communication technologies has enabled a fast and intensive exchange of multimedia content. Also, the intensive development of software packages enables easy and fast downloading, editing of audio contents. However, this situation also affects malicious users, which leads to problems related to copyright protection. [1] - [3]. In order to solve the problem of copyright protection and proving the ownership of multimedia content, the principle of inserting hidden data is used. Inserting hidden digital data is called watermarking [4], [5]. The basic features of a digital watermark are insensitivity, robustness, capacity, non-inversibility and the ability to provide secure proof of ownership. [6]. A watermark can be: a) visible and b) invisible. An invisible watermark is inserted invisibly into another image so that it does not distort the visual characteristics of the image and can be extracted later for the purpose of proving copyright [2]. Many complex transformations are used to insert a watermark into an image, such as DCT [3], [7] (**engl.** *Discrete Cosinuse Transform*), DWT [6], [8] (**engl.** *Discrete Wavelet Transform*), SVD transformation [2],

[7], [8] (**engl.** *Singular Value Decomposition*) and Schur decomposition (**engl.** *Schur Decomposition*, SD) [9], [10].

During digital processing, it is possible to translate the sound into an image for the purpose of visualization and vice versa, to translate the image into a sound [11]-[14]. The technique of converting an image into a sound is called image to sound (IS) mapping (**engl.** *Image to Sound mapping*) [15]-[17], [18]. There are many techniques of converting the image into the sound [19]-[21].

The authors of this paper came up with the idea to test the algorithm for inserting a digital watermark so that after inserting the watermark, the image will be IS mapped in order to obtain an audio signal. The SD watermarking algorithm based on Schur decomposition was used to insert the watermark into the image. [9]. A Notch filter was applied over the audio signal, after which the audio signal was converted by an inverse method into an image from which a digital watermark was extracted. The robustness of the SD algorithm was tested by objective MSE and NC, subjective (visual quality testing) quality measures.

The paper is organized as follows: SD algorithm for insertion and extraction of digital

watermark and Notch filter are presented in section II. Section III describes the experiment and presents the results. The conclusion is given in section IV.

## ALGORITHMS

### A. Schur decomposition

Schur decomposition applied to matrix  $A$  as a results returns two matrices, matrix  $U$  and  $D$ :

$$A = U \times D \times U', \quad (1)$$

where  $U$  is a unitary matrix,  $U'$  is a transposed matrix, and  $D$  is an upper triangular matrix. Two significant characteristics of the unitary matrix  $U$  that refer to the elements of the first column are: a) all elements are of the same sign and b) their values differ slightly [9]. Analysis of a large number of images and their Schur matrices in the transformation of blocks dimensions  $4 \times 4$  showed that the strongest correlation between the elements  $u_{21}$  and  $u_{31}$  [9] therefore inserting of the watermark could be performed by modification of these elements.

### B. SD algorithm

The SD algorithm for watermark insertion, proposed in [9], is based on Schur decomposition and is performed in the following steps:

**Input:** original image  $A_{M \times N}$ , Binary watermark  $W_{M_z \times N_z}$ , block dimension  $M_b \times N_b$ .

**Output:** Watermarked image  $A_w$ .

*Step 1:* The dividing the original matrix  $A$  dimensions  $X \times Y$  is performed on blocks  $H_{M_b \times N_b}$ , where  $X = \lceil M / M_b \rceil$  and  $Y = \lceil N / N_b \rceil$ .

*Step 2:* Applying the Schur decomposition over blocks  $H$ :

$$H_{i,j} = U_{i,j} \times D_{i,j} \times U_{i,j}^T, \quad (2)$$

where  $U$  represent unitary matrix,  $D$  upper triangular matrix and  $1 \leq i \leq \lceil M / M_b \rceil$  and  $1 \leq j \leq \lceil N / N_b \rceil$ .

*Step 3:* Elements  $u_{2,1}$  and  $u_{3,1}$  of each block of matrix  $U$  are modified to obtain a modified block  $U'$  in accordance with the information of inserted binary watermark  $W$ .

Watermark insertion is performed in accordance with the (3) and (4). The binary watermark  $W$  is inserted by a modification made between the second element ( $u_{2,1}$ ) and the third element ( $u_{3,1}$ ) in the first column:

$$w_{i,j} = 1, \begin{cases} u'_{2,1} = \text{sign}(u_{2,1}) * (U_{avg} + T / 2) \\ u'_{3,1} = \text{sign}(u_{3,1}) * (U_{avg} - T / 2) \end{cases}, \quad (3)$$

$$w_{i,j} = 0, \begin{cases} u'_{2,1} = \text{sign}(u_{2,1}) * (U_{avg} - T / 2) \\ u'_{3,1} = \text{sign}(u_{3,1}) * (U_{avg} + T / 2) \end{cases}, \quad (4)$$

where  $\text{sign}(x)$  represent the sign of  $x$  and  $U_{avg} = (|u_{2,1}| + |u_{3,1}|) / 2$ ,  $|x|$  represent absolutely value of  $x$ .

*Step 4:* Reconstruction of the block with inserted watermark:

$$H'_{i,j} = U_{i,j} \times D'_{i,j} \times U_{i,j}^T, \quad (5)$$

*Step 5:* Creating the image with the watermark  $A_w$  from the blocks  $H'$ .

SD algorithm for watermark extraction is performed in the following steps:

**Input:**  $A_w$ - Watermarked image,  $M_b \times N_b$  - block dimension.

**Output:**  $W'_{M_z \times N_z}$  - reconstructed binary watermark.

*Step 1:* Dividing of matrix  $A_w$  dimension  $X \times Y$  on blocks  $H'_{M_b \times N_b}$  is performed, where  $X = \lceil M / M_b \rceil$  and  $Y = \lceil N / N_b \rceil$ .

*Step 2:* Applying the Schur decomposition on the blocks  $H'$ :

$$H'_{i,j} = U'_{i,j} \times D'_{i,j} \times (U'_{i,j})^T, \quad (6)$$

where  $U'$  represent unitary matrix,  $D'$  represent upper triangular matrix and  $1 \leq i \leq \lceil M / M_b \rceil$  and  $1 \leq j \leq \lceil N / N_b \rceil$ .

*Step 3:* Watermark bit extraction  $bw'$  from the matrix  $D'$ :

$$w'_{i,j} = \begin{cases} 0, & \text{if } u'_{2,1} > u'_{3,1} \\ 1, & \text{if } u'_{2,1} \leq u'_{3,1} \end{cases}, \quad (7)$$

*Step 4:* Creating the watermark  $W$  from od extracted bits  $w'_{i,j}$ .

The effect of the Notch filter was realized by applying the filter shown in Fig. 1 [14].

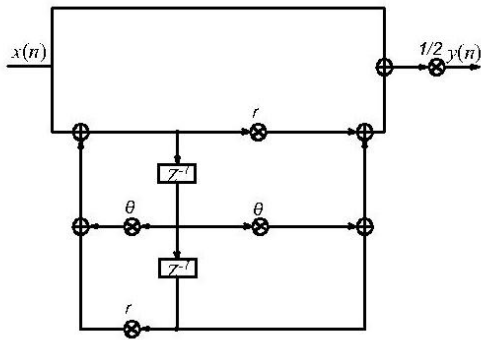

Fig. 1. Block diagram of the Notch filter

## EXPERIMENTAL RESULTS AND ANALYZE

### A. Experiment

For the purpose of testing the influence of Notch filter filtering on the robustness of the extracted digital watermark in IS mapping, the following experiment was performed:

**Input:**  $X$  - Image Cameraman,  $W$  - digital watermark,  $T$  - watermark inserting coefficient,  $M_b \times N_b$ . block dimensions.

**Output:**  $W_e$  - extracted digital watermark.

*Step 1:* Using the SD algorithm, a digital watermark was inserted into the image.

*Step 2:* The image with the watermark is transformed into the audio signal,  $x_w$ .

*Step 3:* A Notch filter was applied to the audio signal with the inserted watermark  $x_w$ , with a non-impermeable  $r$  and the center of non-impermeable of ratio  $\theta$ , a signal  $y_n$  has been got.

*Step 4:* From the signal, over which the Notch filter was applied,  $y_n$ , using the algorithm shown in section II the audio signal is transformed into an image  $A_{WN}$ .

*Step 5:* From the image  $A_{WN}$  a digital watermark has been extracted.

*Step 6:* A comparative analysis of the extracted digital watermark was performed  $W_{eN}$  with original watermark  $W$  by applying objective quality measures.

For an objective quality measurement, the mean square error was applied:

$$MSE = \frac{\sum_{i=1}^M \sum_{j=1}^N (W(i, j) - W_{eh}(i, j))^2}{M \times N}, \quad (8)$$

and normalized correlation coefficient:

$$NC = \frac{\sum_{i=1}^M \sum_{j=1}^N (W(i, j) \cdot W_{eh}(i, j))}{\sqrt{\sum_{j=1}^N (W(i, j))^2} \cdot \sqrt{\sum_{j=1}^N (W_{eh}(i, j))^2}} \quad (9)$$

The Notch filter is described by the differential equation:

$$y(n) = 0.5 \cdot (1+r) \cdot x(n) + \theta \cdot x(n-1) + 0.5 \cdot (1+r) \cdot x(n-2) - \theta \cdot y(n-1) - r \cdot y(n-1) \quad (10)$$

where  $r$  ( $0 \leq r \leq 1$ ) parameter for adjusting the width of the non-impermeable bandwidth,  $\theta$  parameter which is used for adjusting the center of non-impermeable bandwidth:  $\theta = -(1+r) \cdot \omega_c$ , where ( $0 \leq \omega_c \leq \pi$ ).

Amplitude characteristic  $|H|$  is calculated in the z-plane on the circle  $r = 1$ .

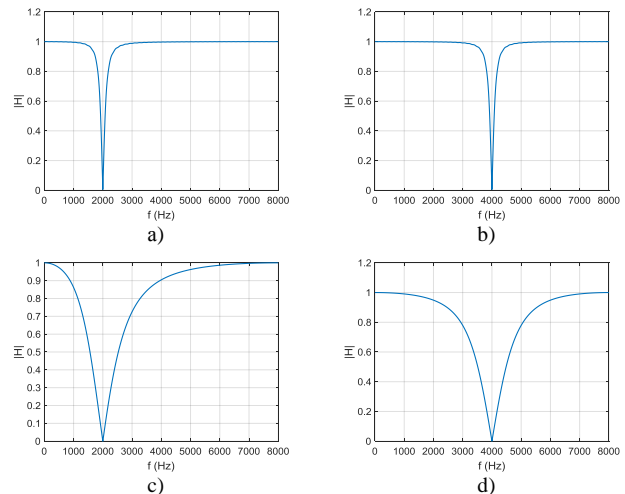
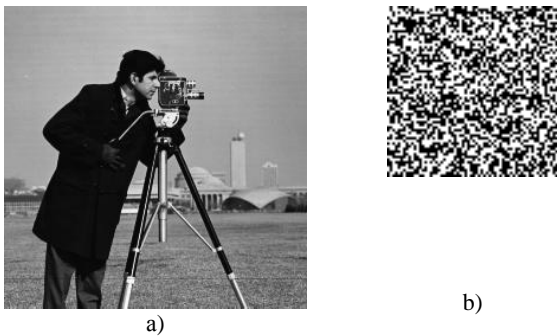

Fig. 2. Amplitude characteristics of Notch filter for: a)  $\omega_c = \pi / 4$  and  $r = 0.9$ , b)  $\omega_c = \pi / 2$  and  $r = 0.9$ , c)  $\omega_c = \pi / 4$  and  $r = 0.5$  and d)  $\omega_c = \pi / 2$  and  $r = 0.5$ .

In the experiment image Cameraman dimension  $256 \times 256$  is used (Figure 3.a) in which a digital watermark dimension  $64 \times 64$  was inserted. Watermark is specially generated for the purposes of the experiment (Figure 3.b). The watermark was generated by randomly generating 50% of black and 50% of white pixels. The image is translated into the sound. The sampling frequency of the obtained audio signal is  $F_s = 16$  kHz. Filtering with a Notch filter was performed with a non-impermeable varied in range  $r = (0: 0.1: 1)$  and

a center of the non-impermeable  $\theta = (0 : 0.1 : 1) \cdot \pi$ . The watermark was inserted using the SD algorithm for insertion and extraction of the watermark, with the coefficient insertion  $T = 0.01$ .

Amplitude characteristics of Notch filter: a)  $\omega_c = \pi / 4$  and  $r = 0.9$ , b)  $\omega_c = \pi / 2$  and  $r = 0.9$ , c)  $\omega_c = \pi / 4$  and  $r = 0.5$  and d)  $\omega_c = \pi / 2$  and  $r = 0.5$ ).

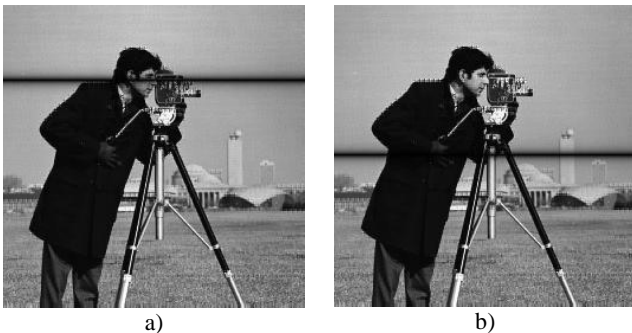

**Fig. 3.** Images used in the paper: a) Lena, and b) Watermark.

Realization of experiment resulted with:

a) in fig. 4. the appearance of the image obtained from the signal over which the Notch filter was applied, has been presented, with the width of the impermeable range  $r$  and the center of the impermeable range  $\theta$ : a)  $r = 0.9$  and  $\omega_c = \pi / 4$ , b)  $\omega_c = \pi / 2$  and  $r = 0.9$ , c)  $\omega_c = \pi / 4$  and  $r = 0.5$  and d)  $\omega_c = \pi / 2$  and  $r = 0.5$ .

b) in fig. 5. the appearance of the extracted watermark from the signal over which the Notch filter was applied, has been presented, with the width of the impermeable range  $r$  and the center of the impermeable range  $\theta$ : a)  $r = 0.9$  and  $\omega_c = \pi / 4$ , b)  $\omega_c = \pi / 2$  and  $r = 0.9$ , c)  $\omega_c = \pi / 4$  and  $r = 0.5$  and d)  $\omega_c = \pi / 2$  and  $r = 0.5$ .



**Fig. 4** Visual appearance of image after applying the Notch filter for: a)  $\omega_c = \pi / 4$  and  $r = 0.9$ , b)  $\omega_c = \pi / 2$  and  $r = 0.9$ , c)  $\omega_c = \pi / 4$  and  $r = 0.5$  and d)  $\omega_c = \pi / 2$  and  $r = 0.5$ .

c) in fig. 6. and fig.7. the diagrams for MSE and NC for the extracted watermark ( $T = 0.01$ ) are presented, from the signal over which the Notch filter (depending on the width of the impermeable band  $r$ ) is averaged for the values  $\theta = (0 : 0.1 : 1) \cdot \pi$ .

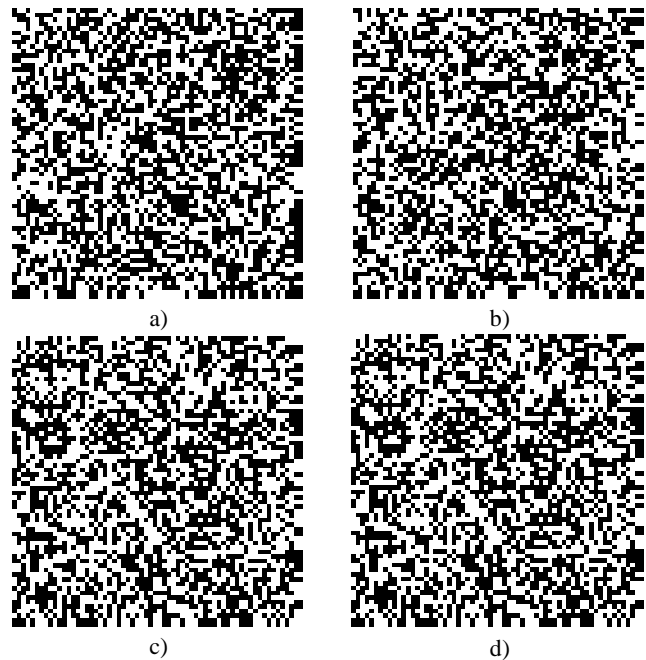

**Fig. 5.** Visual appearance of extracted watermark ( $T = 0.01$ ) after applying the Notch filter for: a)  $\omega_c = \pi / 4$  and  $r = 0.9$ , b)  $\omega_c = \pi / 2$  and  $r = 0.9$ , c)  $\omega_c = \pi / 4$  and  $r = 0.5$  and d)  $\omega_c = \pi / 2$  and  $r = 0.5$ .

## B. Analyze of the results

Subjective comparative analysis of the visual quality of the extracted watermarks presented in fig. 5. (insertion coefficient  $T = 0.01$ ) cannot show the significance of degradation of the extracted watermark.

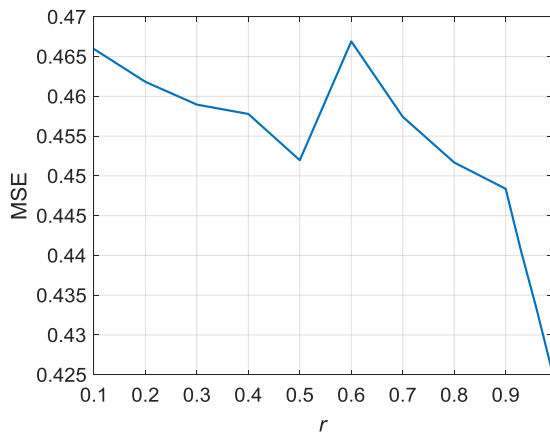

**Fig. 6.** Diagram of MSE for extracted watermark ( $T = 0.01$ ), averaged for values  $\omega_c = (0 : 0.1 : 1) \cdot \pi$ .

Objective analysis was conducted based on the MSE results shown in fig.6. and NC shown in fig.7. The analysis of the results concludes that after applying the Notch filter to the audio signal, the quality of the extracted watermark is better for higher values of the parameter of the impermeable,  $r$ . Based on the results (NC) shown in fig.7. it can be concluded that after applying the Notch filter to the audio signal the quality of the extracted watermark is better for higher values of the parameter of the impermeable,  $r$ . NC grows.

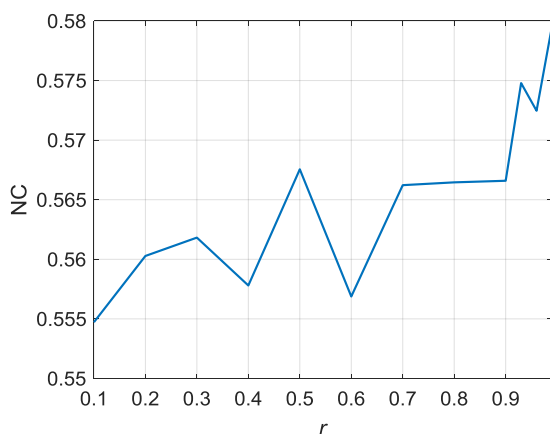

**Fig. 7.** Diagram of NC for extracted watermark ( $T = 0.01$ ), averaged for values  $\omega_c = (0 : 0.1 : 1) \cdot \pi$ .

## CONCLUSION

In this paper is analyzing the robustness of the SD watermarking algorithm in IS mapping, on the Notch (audio signal) filtering. Notch filtering was performed with a impermeability value varied in range  $r = (0 : 0.1 : 1)$  and the center of the impermeable range  $\theta = (0 : 0.1 : 1) \cdot \pi$ . The watermark was inserted

using the SD algorithm for insertion and extraction of the watermark, with the insertion coefficient  $T = 0.01$ . After a detailed objective (MSE and NC) and subjective (visual quality) analysis of the extracted watermark, it was concluded that the quality of the extracted watermark depends on the width of the impermeable range  $r$ .

## REFERENCE

- [1] X. Qi, T. Gao, "Invisible and robust watermarking algorithm based on an image block", J. Image Graph. Vol.22 (6), pp. 719–730, 2017.
- [2] J.Hernandez, M. Amado, F. Perez-Gonzalez, "DCT-domain watermarking techniques for still images: detector performance analysis and new structure", IEEE Trans. Image Process. 9 (January 2000) 55-67.
- [3] R. Liu, T.Tan, "A SVD based watermarking scheme for protecting rightful ownership", IEEE Trans. Multimedia 4 (1) (march 2002) 121-128.
- [4] W. Al-Nuaimy, M. A.M. El-Bendary et al., "An SVD audio watermarking approach using chaotic encrypted images" *Digital Signal Processing* No 21, p.p 76-779, 2011.
- [5] K. Khaldi , A.-O. Boudraa , "Audio watermarking via EMD, IEEE Trans. Audio Speech Lang. Process. Vol. 21 (3) pp. 675–680, 2013.
- [6] W.Chu, "DCT-based image watermarking using subsampling", IEEE Trans. Multimedia 5 (1) (March 2003) 34-38.
- [7] A.Reddy, B.Chatterji, "A new wavelet based log-watermarking scheme", *Pattern Recognition Lett.* 26(may 2005) 1019-1027.
- [8] P.Kumsawat, K.Attakitmongcol, A.Srikaew, "Multi wavelet-based image watermarking using genetic algorithm", *Proceedings of the IEEE TENCON Conference*, november 2004, pp.275-278.
- [9] Q.Su, Y.Niu, X.Liu, Y.Zhu, "Embedding color watermarks in color images based on Schur decomposition", *Optics Communications*, 285 (2012) p.p. 1792-1802.
- [10] G.H. Golub, C.F. Van Loan, *Matrix computations*, Johns Hopkins University Press, Baltimore, 1989.
- [11] H. Kameoka, M. Nakano, K. Ochiai, Y. Imoto, K. Kashino, S. Sagayama "Constrained and regularized variants of non-negative matrix factorization incorporating music-specific constraints". In: *Proc of ICASSP 2012*. p. 5365–8.

- [12] H. Tachibana, N. Ono, S. Sagayama, "Singing voice enhancement in monaural music signals based on two-stage harmonic/percussive sound separation on multiple resolution spectrograms". *IEEE Trans Audio Speech Lang Process* 2014;22(1):228–37.
- [13] Z. Goh, K-C. Tan, BTG. Tan. "Postprocessing method for suppressing musical noise generated by spectral subtraction". *IEEE Trans Speech Audio Process* 1998;6 (3):287–92.
- [14] J. Dennis, HDZ. Tran, ES. Chng "Analysis of spectrogram image methods for sound event classification". In: Proc of INTERSPEECH 2014. p. 2533–7.
- [15] K. Arata, "On sound signal processing in image to sound mapping technique", *Applied Acoustic*, Vol. 117, pp. 1-11, 2017.
- [16] M. Slaney "Auditory model inversion for sound separation". In: Proc of ICASSP 1994. p. 77–80.
- [17] PBL. Meijer "An experimental system for auditory image representations". *IEEE Trans Biomed Eng* 1992;39(2):112–21
- [18] A. Haigh, DJ. Brown, P. Meijer, MJ. Proulx. "How well do you see what you hear? The acuity of visual-to-audio sensory substitution". *Front Psychol* 2013;4:1–13.
- [19] "Coagula".  
<<http://www.abc.se/re/Coagula/Coagula.html>.
- [20] "MetaSynth".  
<<http://www.uisoftware.com/MetaSynth/index.php>>.
- [21] <http://javoice.joomlart.com/>.